



KOMPTECH
TECHNOLOGY FOR A BETTER ENVIRONMENT

TURNER FOR
TRIANGULAR WINDROWS



1

TOPTURN X 4500/5000

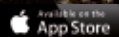

EDITION WITH AUGMENTED REALITY CONTENT

Download the „KompTech LookBeyond!“ app. Scan marked and numbered projects with the „LookBeyond! eye“ to see additional information.



APPLICATION



2

TOPTURN X IN OPERATION

HIGHLIGHTS

- » Large-dimensioned turning drum for high throughput and complete mixing
- » Wheel drive for outstanding traction and quick mobility
Track drive for maximum mobility on unpaved
- » Wide application area:
Composting of MSW, green waste, biowaste, sewage sludge, treatment of contaminated soils, mixing of ores

The Topturn X series is getting a new member. With the Topturn X5000, Komptech presents a modern machine with the ideal combination of performance and design features. The Topturn X4500 has proven itself as a starter machine for smaller compost facilities. The new wider Topturn X5000 is the perfect machine for the five metre wide by two metre tall windrows used at many larger facilities.

With their sturdy frames, powerful hydraulics and large drums, both turners are ready to handle any work situation. There is a choice of two power levels - 205 or 250 kW for the X5000, 151 or 205 kW for the X4500. That lets customers choose the most efficient model for their particular needs. A comfortable cabin, with power lift if desired, and roomy maintenance platforms that fold out hydraulically are further plus points.



3

Composting of municipal solid waste



4

Composting of green waste, biowaste



5

Composting of sewage sludge

COMPOSTING PROCESS

We at Komptech have been working intensively on composting for more than 25 years. The result of close collaboration with experts in science, agriculture and mechanical engineering is machines that ensure maximum ecological and economical efficiency.

In windrow-composting pure green waste, mixing with organic waste and sewage sludge, and for residual and household waste, the rotting process is controlled by turning. The turning process must improve ventilation and provide thorough mixing of the different rotting zones. The Topturn X was developed to do just that. The combination of large drum with conveyor and thrower blades and the powerful drive ensures that the turner

leaves the perfect windrow behind it as it goes. Loosely stacked, with a triangular cross section, the windrow draws in the necessary fresh air through a chimney effect. Decomposition is aerobic and odors are kept down. The thorough mixing evens out moisture and nutrient differences, creating the perfect conditions for microorganisms.

INSIDE THE MACHINE

DESIGNED TO TAKE ANYTHING

The frame is designed for the most heavy-duty applications. The sturdy, buckle-resistant design enables maximum performance even with the heaviest materials. The generously dimensioned turning drum is mounted on the frame and provides additional stability. If required by the job, the frame together with the drum can be raised 380 mm on each side of the chassis with a central telescopic unit.

LIFT-OFF TO WORK

Getting started is safe and convenient. Entry into the cab is through a front panel door. Two hydraulic lift arms then swivel the cab from the entry position on the ground into the working position centrally above the tunnel. When the cab is in the transport position the turner is very compact, simplifying multi-site use.

POWERHOUSE POWER PLANT

The turning performance of the Topturn X is controlled by the operator, not by the machine. The performance of the CAT® engine is perfectly suited to the machine. A powerful cooling system for the engine and the hydraulic system keeps the machine in the “green” range, even in hot weather.

01

Spacious comfortable cabin
(optional with lift function)

02

Diesel engine in 2 output levels
X4500: 151/205 kW
X5000: 205/250 kW

03

Service steps and
platform simplify
maintenance

04

1.2 m diameter drum
with double-use blades

05

Massive plough blades
for reliable track cleaning

TECHNOLOGY AND FUNCTION



DRIVE

- » Modern CAT® diesel engine
- » Hydraulic drive with separate circuit for drive and drum function
- » Powerful cooling system



FRAME

- » Designed for heavy duty application
- » Frame mounted drum provides stability
- » Telescopic frame enables movement in all situations



LIFT CABINE

- » Compact size with minimal transport height
- » Comfortable entry from the ground
- » Symmetrical arrangement for perfect panoramic view in working position



TURNING DRUM

- » Large diameter for perfect mixing
- » Infinitely adjustable speed, reversible
- » Wear resistant tools with armouring



USER FRIENDLY

- » Ergonomic working place
- » Monitoring of operational status
- » Simple and logical controls



SERVICE FRIENDLY

- » Wide opening side covers
- » Service steps for easy access
- » Automatic central lubrication (Option)



TURNING & DRIVE

PERFECT TURNING

HIGHLIGHTS

- » Large drum diameter ensures mixing of the entire cross-section of the windrow
- » High centrifugal mass of drum provides continuous, engine protecting work
- » Wheel drive or Track drive
- » Comfortable cabin with a lot of space and intuitive controls

A large, powerful hydraulically driven drum with efficient conveyor and throwing blades accelerates the turning and rotting processes. It makes sure all materials are mixed before passing through the drum, so nothing is missed. Together with the reversibility feature, the steplessly adjustable drum speed lets the operator adjust to any situation: low speed at start-up, top speed in the windrow and low reverse at the end of the windrow.

The hydraulic plough shaped guide blades steer the material into the feed area and keep the lane clean. Their sturdy design allows driving within overlapping windrows. A separate hydraulic circuit delivers the power to the drive system. Wheel or track drive? At Komptech, this is a decision we leave to our customers.



WHEEL DRIVE

The wheeled chassis has impressive benefits on asphalt and concrete. Power is delivered to all four wheels, providing on the spot turning, high traction and quick maneuverability. Combined with the comfortable ride provided by tires, these are persuasive arguments.

- » The best traction on paved surfaces
 - » Tough long-life tires
 - » Comfortable ride due to dampening effect of tires
 - » Quick maneuverability with a 2nd gear up to 6 km/h
-



TRACK DRIVE

The tracked chassis is the ideal option for unpaved ground. Even on difficult terrain, engine power is converted effectively into forward movement. The open track design enables simple cleaning.

- » The best traction on difficult terrain
 - » Wide chassis for low ground pressure
 - » Open track chassis for simple cleaning
 - » Low-wear, rubber-coated, self-cleaning drive plates
-



ON TOP OF THE SITUATION

Things look good from the driver's seat. Centered over the middle of the window, the driver has a good view to both sides and everything under control. On the right is the responsive joystick directional and speed control. On the left are the function controls. Even on all-day jobs, the driver stays comfortable and focused, thanks to noise insulation, tinted glass, A/C, radio and MP3 player, and load-dependent automatic steering.

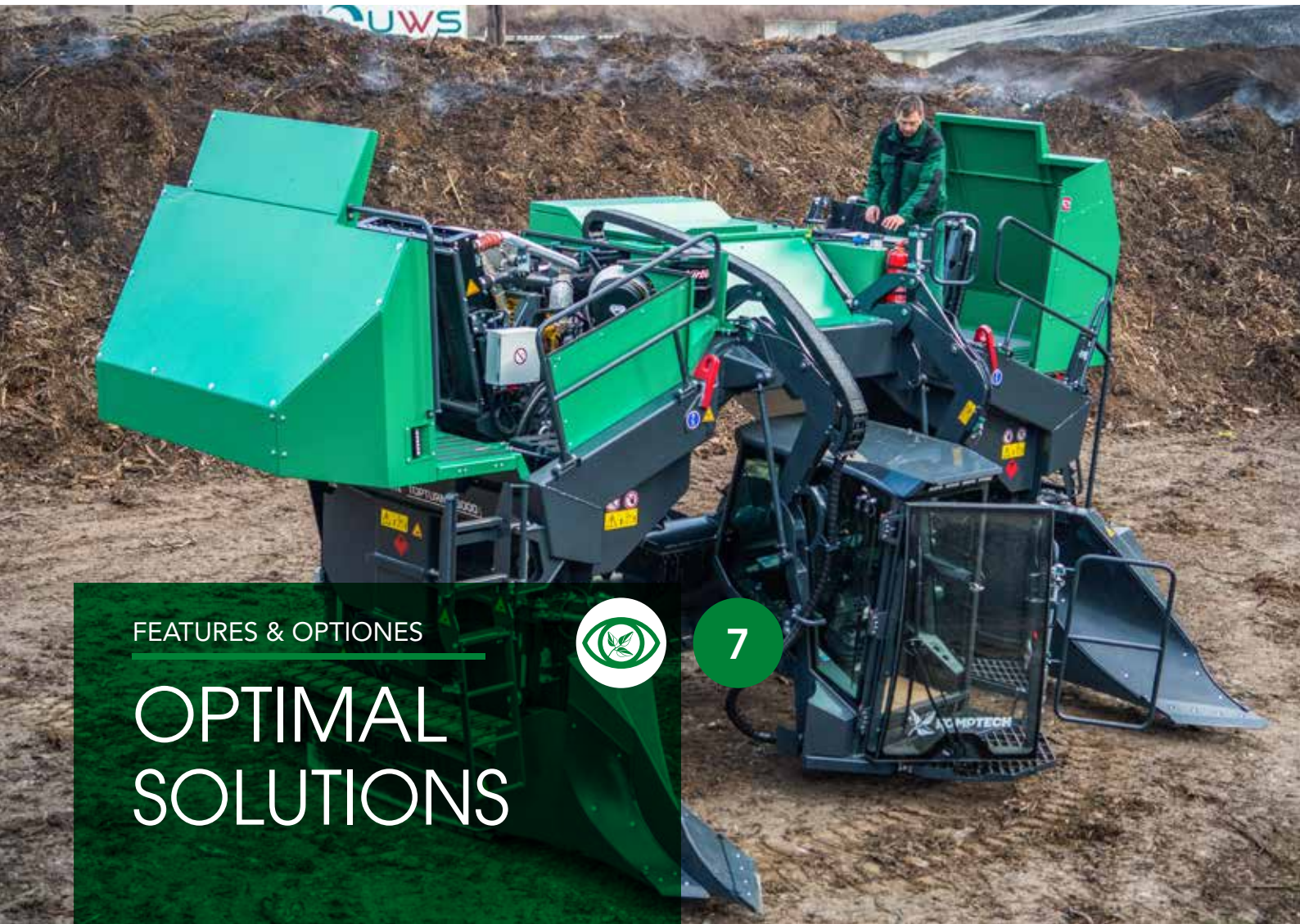

FEATURES & OPTIONS



7

OPTIMAL SOLUTIONS

HIGHLIGHTS

- » Easy maintenance access with ladders and platforms integrated in the body
- » Double use of throwing tools for low wear costs
- » Watering option with powerful hose system
- » Option scraper device for uptake of the lowermost windrow layer

A press of a button turns the left and right body panels into roomy maintenance platforms with convenient access steps so the operator can reach all maintenance points safely and easily. All filters and fluid fill openings are in easy to reach positions. Special maintenance doors in the tunnel and drum bearings accessible from the outside underline the exceptional maintenance-friendliness of the new Topturn X series.

Komptech also thought about the wear costs. The high-strength steel turning blades can be turned 180 degrees when they get worn, for a whole new use cycle before needing to be replaced.



ADVANTAGE TELESCOPING FRAME

In addition to the great advantage of "running free," the telescoping frame makes access to the drum drive and bearings easier. This really simplifies maintenance of these items.



FROM WORKING TO TRANSPORT POSITION QUICKLY

Fold in the clearing blades hydraulically, turn them into the tunnel and lock them, move the cabin to transport position, and the Topturn is ready to travel for multi-site use.



QUICK MANEUVERING

The "Fast"-versions of the Wheel-drive have a second speed level, meaning maneuvering around saves far more time because of the up to 50% increase in speed in relation to the turning speed.



WATERING CORRECTLY

A powerful hose system which is used for watering is unwound off a drum by the turner and wound up on the drum with a remote control device. During the turning process, water is poured into the material across a wide area via an impact nozzle.



ARMORED TOOLS FOR PROLONGED USAGE

For materials with high abrasive content (sewage sludge, sand, glass), carbide coating and an armored drum body reduce wear and maintenance costs.

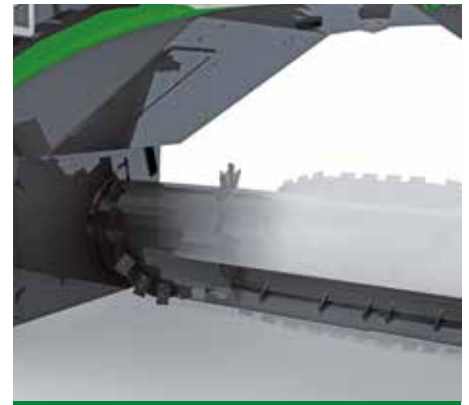

TAKE UP EVERYTHING WITH THE SCRAPER DEVICE

A patented scraper device ensures the lowermost windrow ground layer, a potential source of odours, is not left behind. A quick-coupling system allows the scraper to be mounted/removed in just a few quick steps.



TOPTURN X4500

TOPTURN X5000

	TOPTURN X4500	TOPTURN X5000
Drive		
Diesel engine:	CAT® C7.1	CAT® C7.1/ CAT® C9.3B
Power (kW/PS):	151/205 or optional 205/278	205/278 or optional 250/340
Turning unit		
Turning drum diameter (mm):	1200	1200
Turning drum rpm:	0-195	0-195
Windrow dimensions		
Windrow width (mm):	4500	5000
Max. windrow height (mm):	2200	2200
Windrow cross-section at 45° repose angle (m²):	5.1	6.2
Travelling speeds (I standard, II optional)		
Wheel (km/h):	I: 0-4 II: 0-6	I: 0-4 II: 0-6
Track (km/h):	I: 0-4	I: 0-4
Dimensions L x W x H		
Transport dimensions Wheel (mm):	4851 x 2996 x 3319	5357 x 2996 x 3324
Transport dimensions Track (mm):	4851 x 2550 x 3288	5357 x 2550 x 3293
Working dimensions Wheel (mm):	4484 x 5080 x 4056(+380)	4484 x 5580 x 4056(+380)
Working dimensions Track (mm):	4126 x 5080 x 4025(+380)	4124 x 5580 x 4025(+380)
Weight		
Wheel (t):	~ 14.5	~ 16.0
Track (t):	~ 15.0	~ 16.5
Throughput (dependent on material)		
Throughput performance (m³/h):	up to 3000	up to 4000
Options		

Engines with emission class Tier 3/Stage IIIA, Tier 4 Final/Stage IV or V (dependent on engine type), Two speed levels, lift-cabin, central lubrication, scraper, protective ventilation, watering system etc.

TOPTURN X4500

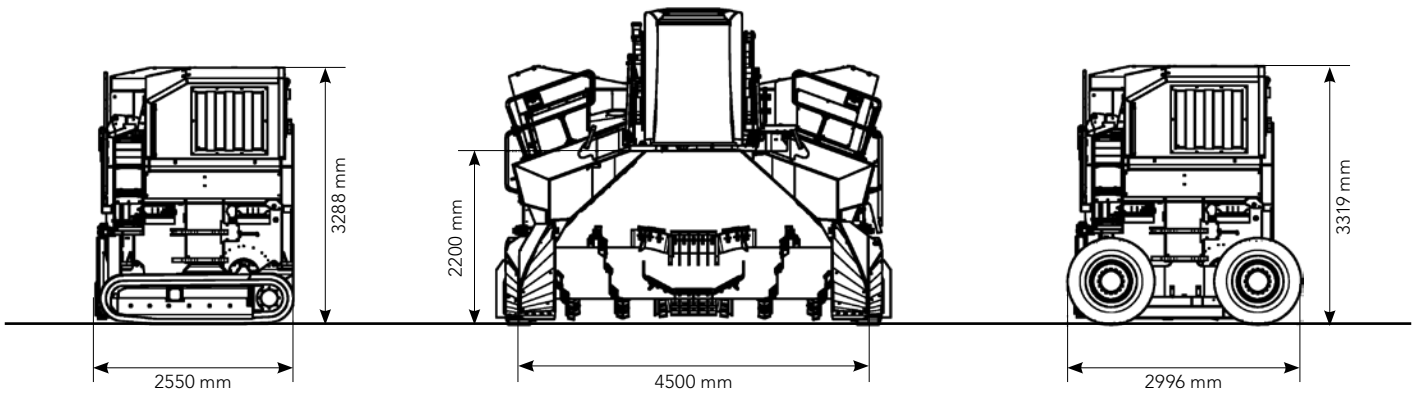

Track transport dimensions

Working position

Wheel transport dimensions

TOPTURN X5000

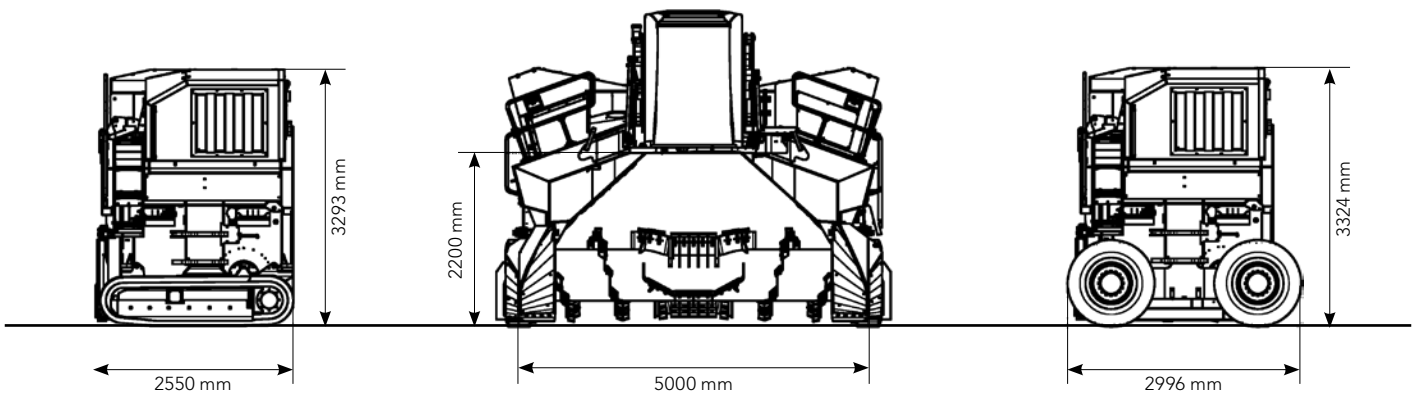

Track transport dimensions

Working position

Wheel transport dimensions

TECHNOLOGY FOR A BETTER **ENVIRONMENT**



Komptech GmbH
Kühau 37, A-8130 Frohnleiten, Austria
[t] +43 3126 505 - 0
[f] +43 3126 505 - 505
[e] info@komptech.com

www.komptech.com

We reserve the right to make technical changes in the course of ongoing development. E2018